

MULTI-DWELLING INTEGRATION

CRESTRON HOME™

AVLinkPro™ is a leader in video intercom communication integration.

Today's smart residence environments call for interaction with a variety of technologies that provide inter-communication at some level to allow for security and safety as well as amenities to benefit the resident.

In the Crestron Smart home environment, AVLinkPro™ has provided a partner solution since early 2018 that allows for full functionality within all Crestron environments for audio and video communication.

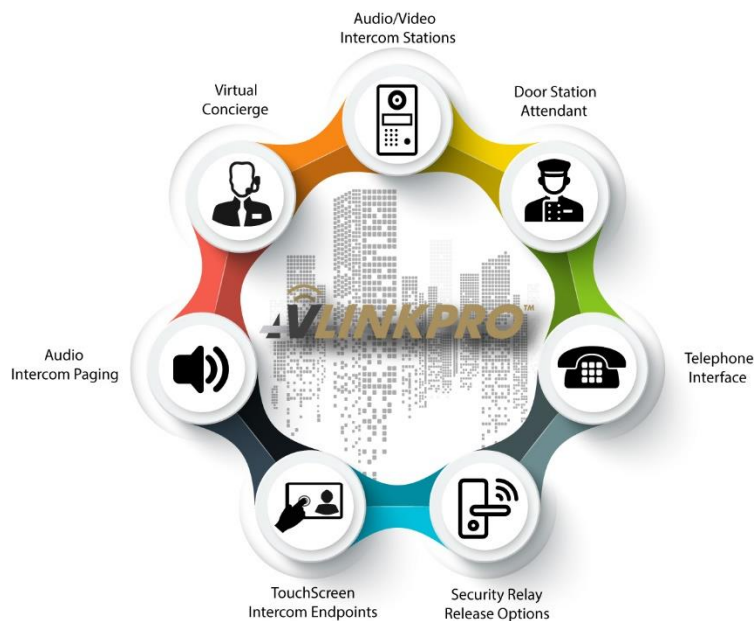

Why this solution is important to MDU integration?

- Video intercom from a shared entry point is a vital security amenity
- Residents want to have a communication path to concierge
- The ability to preview a visitor before allowing access is a key feature
- Residents want to be able to allow visitors to gain access to enter
- Integration within the Crestron ecosystem benefits the system, the resident as well as the building management and security position
- Such an amenity compliments the building security and convenience
- With AVLinkPro, Crestron systems can control elevators and access controls
- Real estate properties prove to be more attractive with such amenities



A Famous Address in New York City Offers Hi-Tech Amenities

When developer Michael Shvo acquired the 20 story building located on the corner of 54th Street in the heart of the Upper Fifth Avenue in Manhattan, he anticipated a new branded residential tower by the Mandarin Oriental Residences. The Mandarin Oriental Residences at 685 5th Avenue, part of the world famous Mandarin Oriental Hotel Group. It is a distinctive luxury residence with the comforts of a private home combined with the unsurpassed amenities and legendary service of Mandarin Oriental. These turnkey residences offer the full comforts of home with views of mid-town Manhattan and advanced amenities such as Crestron smart home automation and control technology. Featuring fully centralized lighting control and heating/cooling control and video intercom communication. The project overseen by SHVO real estate development that includes renovation of the building site to 29 stories as well as management and sales of the residence spaces.

The security and audio video solutions are provided by **Communications Engineering Management (CEM)** of Paramus, NJ, a Crestron Certified, solutions provider for interactive multi-media technology, smart building infrastructure, audio/video consulting and installation for smart home technology at luxury residences. **CEM** reached out to AVLinkPro, a Tier One Crestron partner manufacturer to provide a unique security and communication solution for the individual residences.

The AVLinkPro solution is recognized as the technology leader in communication bridge technology to allow single residence and multiple dwelling spaces connect via intercom and other communication devices.



MDU Communication Solutions

Mandarin Oriental Residences - SHVO Development



65 Luxury Apartments

Studio, 1 & 2 Bedroom Suites with Den Options (625-1500 sq. ft.)

Number of Floors: **28**

Integration in each residence: **Crestron Home**

Total Crestron touch screens dedicated to intercom: **69**

Crestron systems being controlled in each residence:

Lighting, Thermostats, Audio, Video, Shades, Intercom other

Service door entry devices: **DoorBird D2104, D1100** video intercom

The Challenge:

- To provide connectivity for the common concierge intercom through the Crestron Home enabled touch screen panels.
- Provide for Intercom connectivity to main office and public access endpoints.
- Allow the Crestron touch panels in residences to ring from lobby or services.
- To provide all these features in an enterprise level to all end points.
- To integrate the solution given that resident will have their own internet service provider (ISP) and localized Crestron solution.
- To provide a easy deployment solution to meet all residences needs.

The Solution:

AVLinkPro™ provided a fully communication solution by providing the **AVLinkPro™ LP360RM** large scale PBX Bridge system that will manage and coordinate the MDU intercom solution through a network VLAN to each condominium. The **AVLinkPro™ CLIO8+** Layer 3 PoE network switch is installed in each residence to allow for VLAN Connection to the building network without interfering with the residents local router or local ISP.

The **AVLinkPro™ SIPAHOUY Enterprise** platform is utilized to enable maximum communication between endpoints such as building staff and entrance security. AVLinkPro also provided intercom to telephone services so that security staff can manage services entrances at any hour.



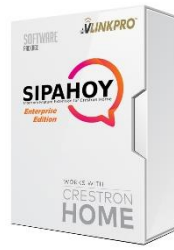

Project includes:

- 1 x AVLinkPro™ LP360 SIP PBX Bridge
- AVLinkPro™ SIP Channel endpoint licenses
- 1 x SIPAHYO Enterprise platform for Crestron Home
- 65 x AVLinkPro™ CLIO+8 PoE Layer 3+ network switches
- 2 x AVLinkPro™ CLIO+24 PoE Layer 3+ Fiber switches
- 2 x AVLinkPro™ RELOGIC 16 Port Digital Access Relays
- AVLinkPro™ Ittendant Intercom to telephone service

ittendant

Crestron Home Residential Intercom Multi Dwelling Unit

Enhanced MDU Door-Station Connection with AVLinkPro™

Connection VIA Internet from common building ISP

Common application using AvlinkPro LP360 or LPRAD

WORKS WITH **CRESTRON HOME**

Dedicated building internet

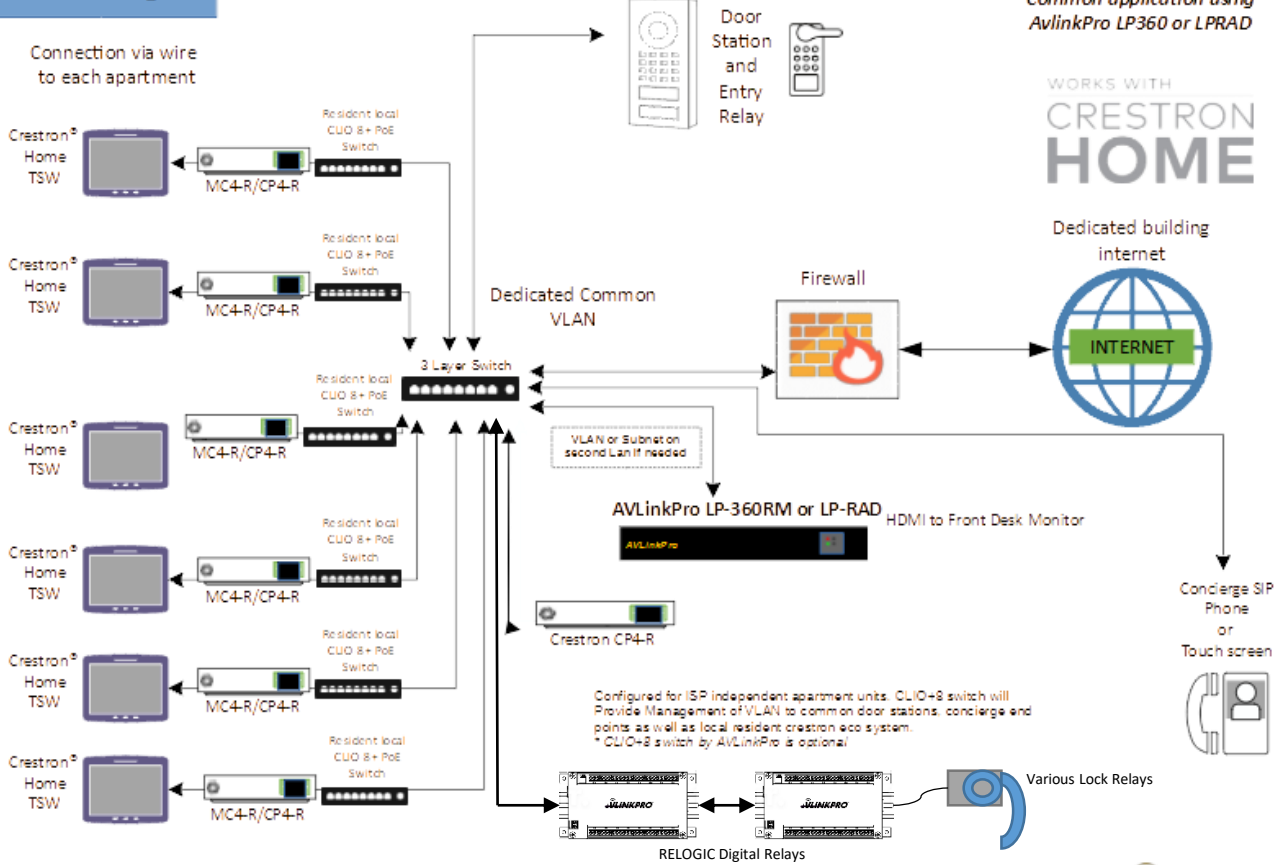

Each residence having independent ISP uses the Avlink-Pro CUO 8+ 2+ layer VLAN enabled network switch



Automation Devices				
Tenant Status: Enabled <input checked="" type="checkbox"/> Enable				
Tenants				
Show	Tenant Name	Email	Actions	
1	APT 54	tesar@gmail.com	<input checked="" type="checkbox"/>	<input checked="" type="checkbox"/>
2	APT 10A	rob@gmail.com	<input checked="" type="checkbox"/>	<input checked="" type="checkbox"/>
3	Apartment 1A	Fyy@gmail.com	<input checked="" type="checkbox"/>	<input checked="" type="checkbox"/>
4	Apartment 20B		<input checked="" type="checkbox"/>	<input checked="" type="checkbox"/>



www.avlinkpro.com

866-937-2833